

KIT Nissan NV350

RHD version

Version Rechtslenkung

Version conduite à droite

Versión volante a la derecha:

Versione guida a destra

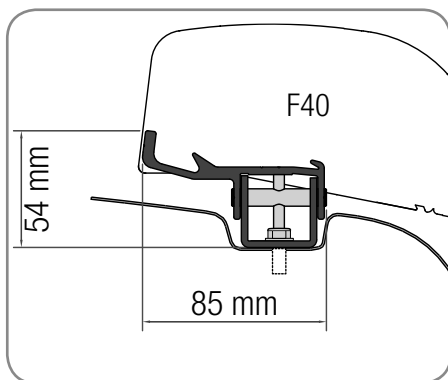

FIAMMA F40VAN

DE	Montageanleitung für die Halterungen
EN	Installation instructions for brackets
FR	Instructions de montage pattes
ES	Instrucciones de instalacion de los estribos
IT	Istruzioni di montaggio staffe

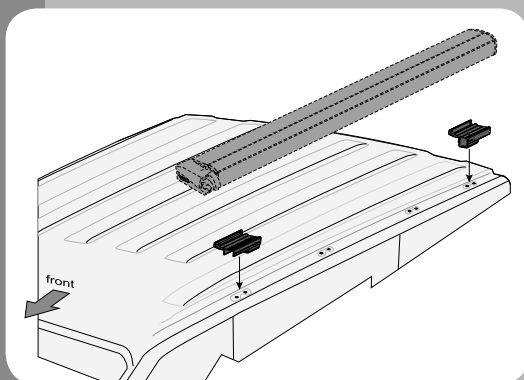

DE Verpackungsinhalt
FR Contenu de l'emballage
IT Contenuto dell'imballo

EN Package contents
ES Contenido del embalaje

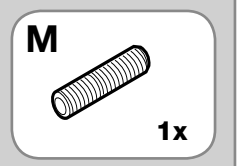
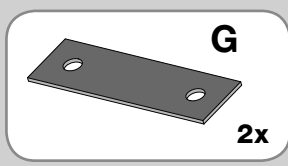
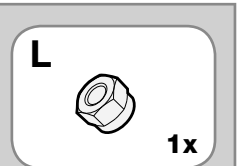
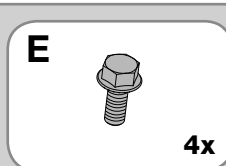
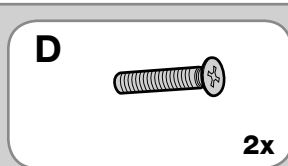
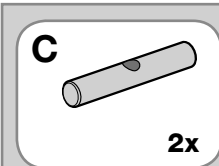
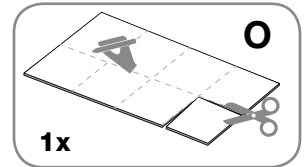
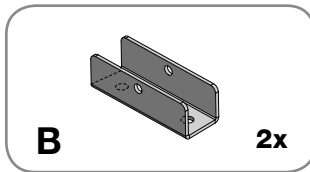
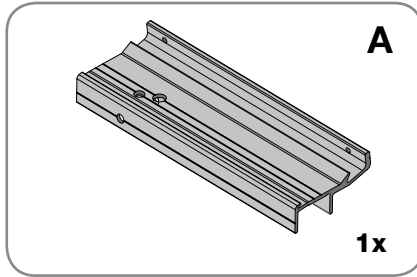
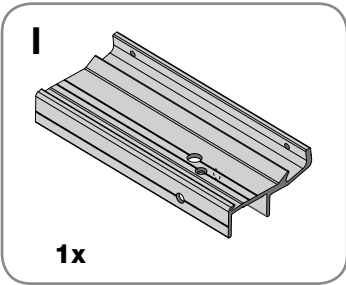
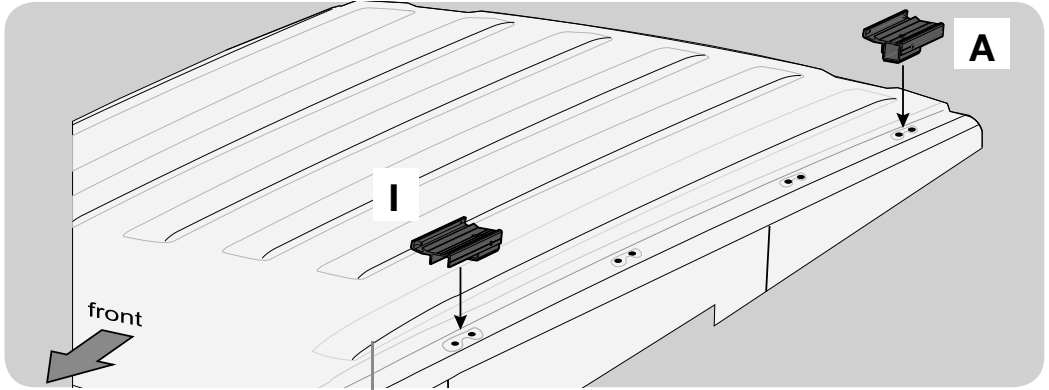

DE Kontrolle bei der Übernahme

FR Contrôle à la réception

IT Controllo al ricevimento

EN Goods receipt inspection

ES Control al recibimiento

DE Bitte kontrollieren Sie, dass alle Einzelteile einwandfrei sind und nicht während dem Transport beschädigt wurden. Wenden Sie sich in diesem Falle an Ihren Händler.

EN Check that nothing has been damaged or deformed during transport. In case of damage please contact the dealer.

FR Contrôler qu'aucune pièce ne soit cassée ou déformée suite au transport. En cas contraire, contacter le revendeur.

ES Controlar que ningún detalle se haya roto o deformado durante el transporte. En este caso contactar al revendedor.

IT Controllare che nessun particolare sia rotto o deformato a causa di errori di trasporto. In questo caso contattare il rivenditore.

DE Montageanleitung

FR Instructions de montage

IT Istruzioni di montaggio

EN Installation instructions

ES Instrucciones de montaje

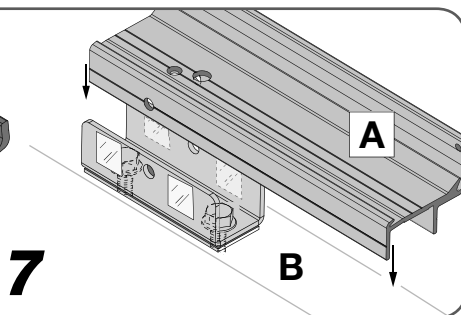
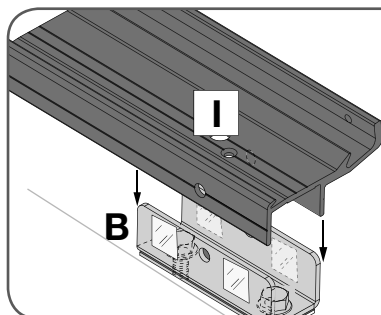
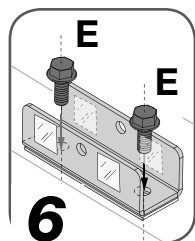
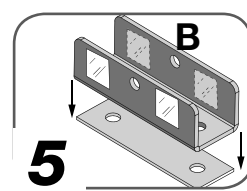
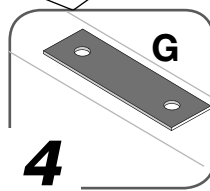
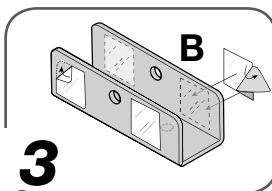
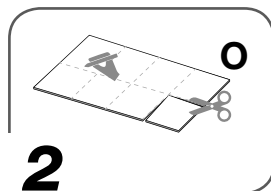
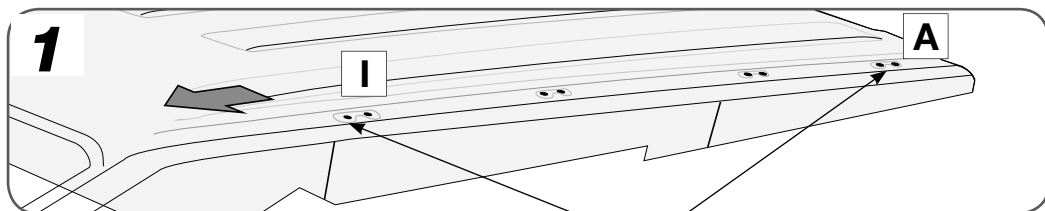

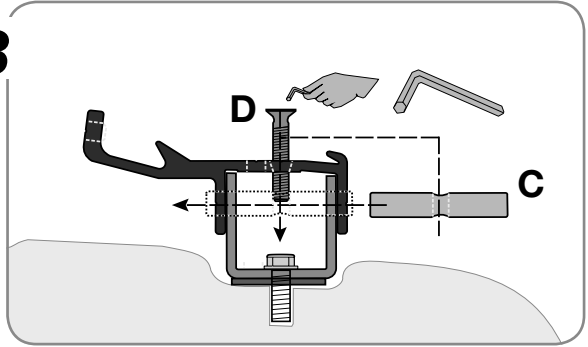
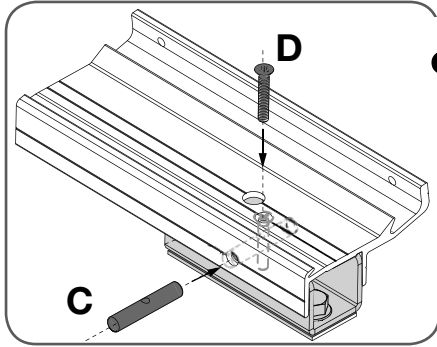

DE Vor dem Anziehen der Schraube, die Position der Markisen kontrollieren, welche das komplette Öffnen der Schiebetür ermöglichen muss.

EN Before tightening the screws, make sure that the awning position doesn't prevent the opening of the rear door.

FR Avant de serrer les vis, vérifier la position du store qui doit permettre l'ouverture complète du hayon arrière.

ES Antes de apretar los tornillos, asegurarse de que la posición del toldo no interfiera con la apertura completa de la puerta trasera.

IT Prima di stringere le viti, fare un controllo del posizionamento del tendalino per consentire l'apertura completa del portellone posteriore.

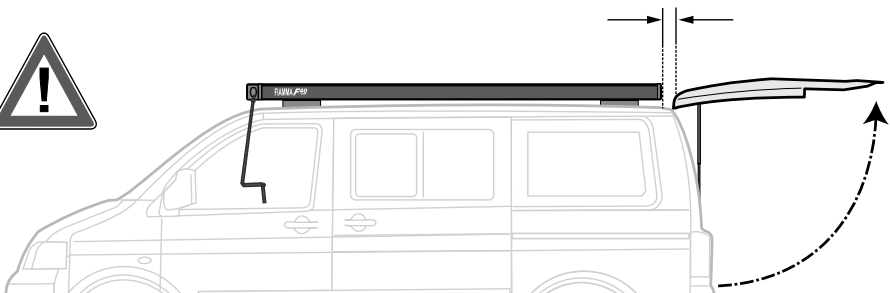

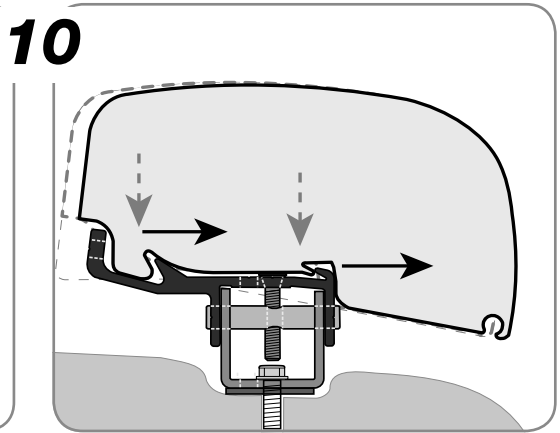
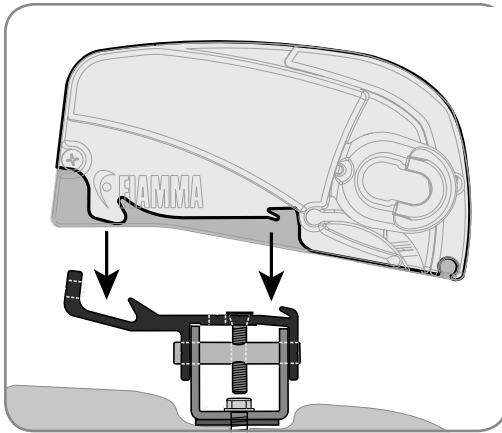
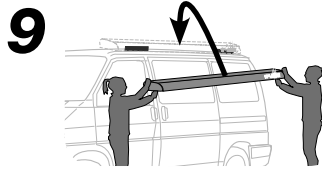

DE Bitte immer die Sicherheitsschrauben benützen.

EN Please use always the security screw.

FR Utilisez toujours les viss de sécurité.

ES Poner siempre los tornillos de Seguridad.

IT Mettere sempre le viti di sicurezza.

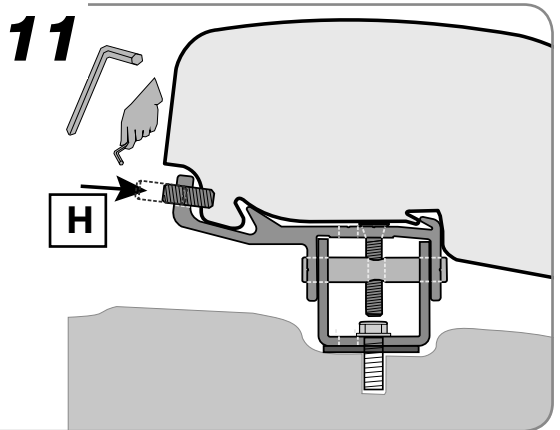

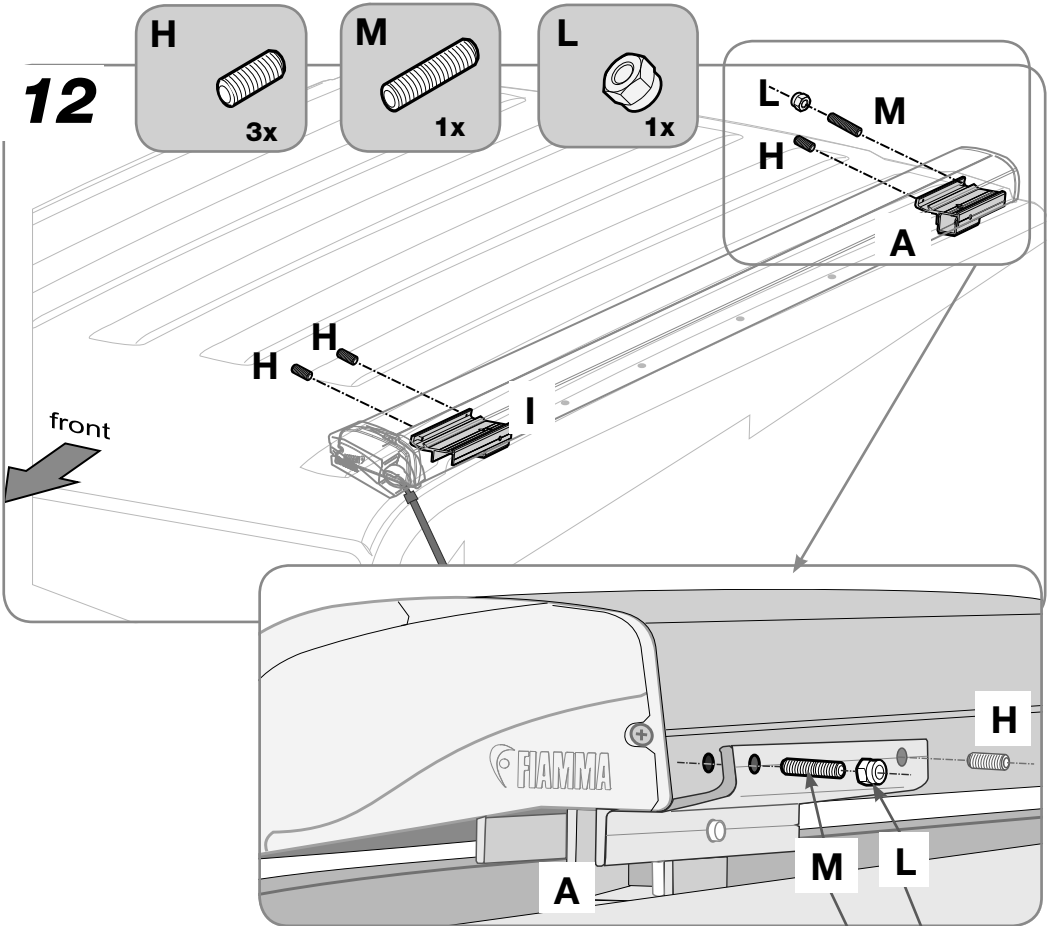

DE Bitte immer die Sicherheitsschraube mit der Mutter anbringen.

EN Please use always the security screw with nut.

FR Utilisez toujours la vis de sécurité avec écrou.

ES Poner siempre el tornillo de seguridad con tuerca.

IT Mettere sempre la vite di sicurezza con dado.

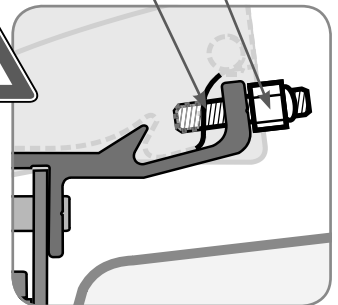

DE Montageanleitung
FR Instructions de montage
IT Istruzioni di montaggio

EN Installation instructions
ES Instrucciones de montaje

DE **ACHTUNG** Regelmäßig die Befestigung für die Halterungen kontrollieren. Achten Sie vor allem nach den ersten Kilometern darauf, dass sich die Haltebügel nicht verschoben haben.

EN **ATTENTION** Periodically check the brackets to make sure they are firmly attached (especially after the first kilometers) make sure the bolts are not loose and that holding brackets have not shifted.

FR **ATTENTION** Contrôler périodiquement l'état de fixation des pattes (surtout après les premiers kilomètres) en s'assurant que les supports de fixation n'aient pas bougé.

ES **CUIDADO** Controlar periódicamente el estado de fijación de los estribos (sobre todo después de los primeros Kms) asegurándose que no se desplacen.

IT **ATTENZIONE** Controllare periodicamente lo stato di fissaggio delle staffe (soprattutto dopo i primi chilometri) assicurandosi che le stesse non si siano mosse e che i serraggi siano corretti.

DE Garantie Fiamma
FR Garantie Fiamma
IT Garanzia Fiamma

EN Warranty Fiamma
ES Garantía Fiamma

DE Im Falle einer Vertragswidrigkeit der Ware, kann der Verbraucher unter den erforderlichen Voraussetzungen gegenüber dem Verkäufer von dem Garantieanspruch zu den festgelegten Bedingungen gemäss den lokalen Rechtsvorschriften Gebrauch machen.

EN In case of defects with regards to materials and manufacturing, the customer is entitled to the warranty in accordance with local laws and regulations of the country in which the product was purchased.

FR En cas d'un défaut de conformité du produit, le consommateur pourra faire valoir ses droits de recours en garantie selon les modalités prévues par les dispositions légales locales, pour autant que les conditions de recours soient remplies.

ES En caso de fallos o defectos de material y de fabricación, el cliente puede hacer valer la garantía de acuerdo con las leyes y reglamentaciones del país en el que el producto haya sido comprado.

IT In caso di difetto di conformità dei beni, il consumatore potrà far valere nei confronti del venditore la garanzia secondo le modalità previste dalle disposizioni di legge locali, ove ne ricorrano i presupposti.



fiamma.com

All rights reserved.

Fiamma S.p.A. reserves the right to modify at any time, without notice, prices, materials, specifications and models or to cease production of any model.

98655Z041

Fiamma SpA - Italy
Via San Rocco, 56
21010 Cardano al Campo (VA)

R0_IS_98690-943_revA

Fiammastore